

Specification for semi-automatic strap seal machine

NO	Items	Data
1	Machining strip width range (mm)	30~55
2	Machining strip thickness range (mm)	0.3~0.9
3	Seal inner width range (mm)	10~100
4	Steel material	Zinc coated steel coil
5	Feeding range (mm)	380
6	Main motor power (kw)	1.1
7	Seal inner width (mm)	16, 19, 25, 32, 40
8	L*W*H (mm)	1100*700*1200
9	Weight (kg)	300
10	Model	FR-5

How to install the machine

半自动钢带打包

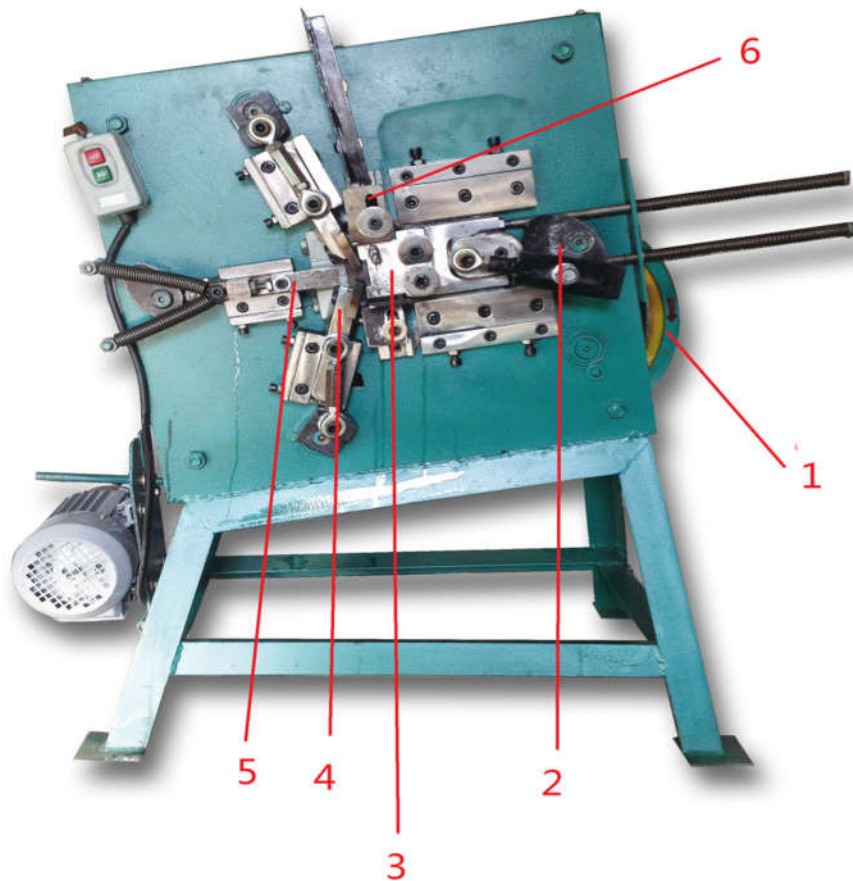

1.皮带轮 Pulley belt

2.偏心轮 Eccentric gear

3.模具 Mould

4.小铲 Shovel

5.顶芯键 Underprop

6.剪口 Shearing platform

1. Connect the power supply, make sure the running direction of the belt pulley(1) same as the arrow direction on the pulley.
2. Turn off the machine, run the machine by hand through pulley. Make the Mould(3) to the top place.
3. Feed the raw material into the machine through the shearing platform(6)
4. Do not turn on the machine! Produce 3-5 seals manually through the belt puley. Make sure every seal can be pushed out.
5. Then turn on the machine to produce the seals.